

KODIAK

PVC PANELS

**THE STRONG CHOICE FOR
PVC WALL & CEILING PANELS**





Kodiak interlocking panels provide a smooth finish with no exposed fasteners.



Kodiak Wall & Ceiling Panels are a sanitary, PVC based product designed to clad indoor wall and ceiling surfaces for any type of project.

APPLICATIONS:



ALSO AVAILABLE IN
GREY

Features & Benefits:

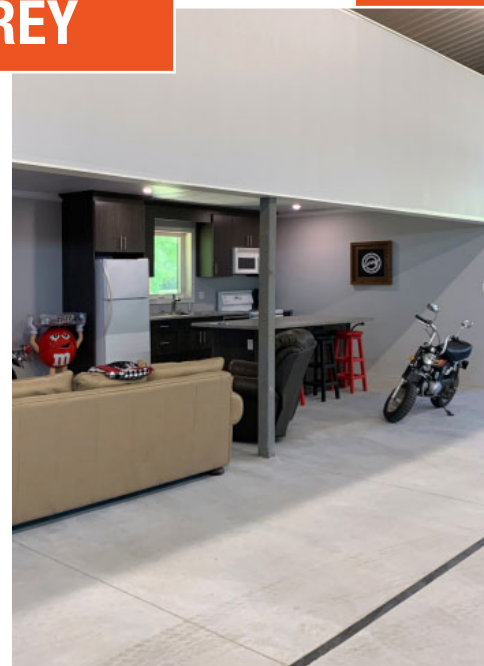

- Industry leading wall thickness gives Kodiak PVC outstanding strength not found in other panels.
- KODIAK PVC Panels are 16" wide and come in 8, 10, 12, 14, 16, 18 and 20 foot lengths.
- Made from 100% virgin PVC, Kodiak is highly resistant to chemicals and unaffected by moisture making it an ideal replacement for conventional wall systems like painted drywall.



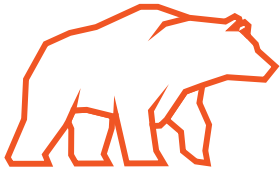

KODIAK PVC PANELS

THE STRONG CHOICE FOR PVC WALL & CEILING PANELS

SPECIFICATIONS

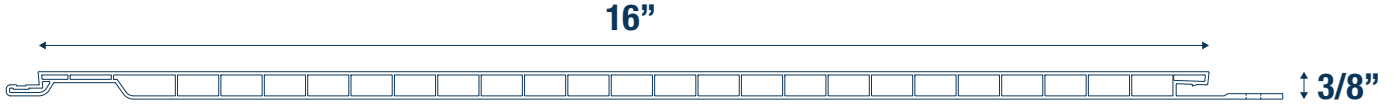

- KODIAK PVC Panels are 16" wide and come in 8', 10', 12', 14', 16', 18' and 20' lengths.
- Custom lengths are available.
- KODIAK PVC Panels are white with matching trims.
- **NEW!** KODIAK GREY is also available in 12', 16', & 20' lengths with matching trims.

Kodiak's unique expansion channel allows for easy install and a tight connection between panels.

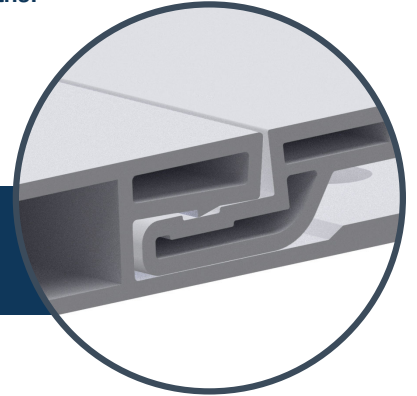

Ratings

- Flame Spread value of 20 (CAN/ULC S102.2) & 15 (ASTM E84). Always refer to local fire and building codes before installing.
- Meets CFIA (Canada) and FDA (U.S.A.) approval requirements for indoor applications.
- 99.9% kill for bacteria and fungi using ISO 22196 test.

Trims and Flashing

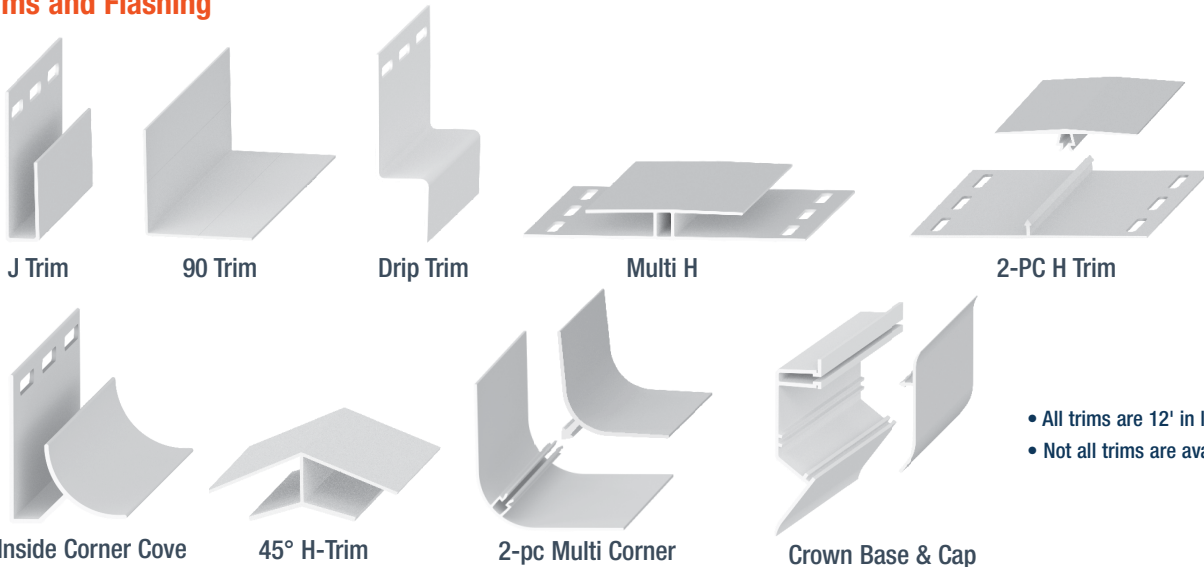

- All trims are 12' in length.
- Not all trims are available in Grey.

Fasteners

- Domtek recommends our #10 x 1-1/2" pancake head fastener for Kodiak installations.
- For high-moisture applications, we recommend our stainless steel option.

